



COLUMN DRILLING MACHINES SERIE TS-32-35

- Manual feed
- Geared drive
- Fixed headstock and displaceable table

STANDARD EQUIPMENT

- Frontal wheel for fine sensitive feed
- Lighting equipment
- Main spindle/shank unit, and high quality steel gears, fully treated and grounded.
- Automatic tool ejector
- MT main spindle, with threaded nose and protection nut
- Adjustable depth stop, with scale in metric or inches
- Working table with 2 "T" slots, rotating around the column with vertical displacement by manual command
- Plate/base with "T" slots
- Speed connection and selection general switch/commuter
- Selector for turning direction
- Emergency push-button
- Electrical equipment at low voltage
- Drill guard with stop micro (CE countries)

EXTRA EQUIPMENT

- Turning for tapping
- Tapping system by cycle timer
- Tapping system by lead screw with braking device
- Rotating table
- Rotating and tilting table
- Drill guard for multispindle headstock
- Automatic feed by hydroblock
- Multispindle headstocks
- Cross tables
- Indexing tables, mechanical, pneumatic, electric, CNC
- Vices
- 2, 3 or 4 jaws chucks
- Drill chucks
- Reduction sleeves
- Flowdrilling
- Tap holders
- Collet holders, set of collets, key, nut and box



CHARACTERISTICS

MODELS	TS.32	TSR.32	TS.35	TSR.35
CODE	T0532	T1032	T0535	T1035
DRILLING CAPACITY IN STEEL OF 70 KGRS	32 mm		35 mm	
TAPPING CAPACITY IN STEEL OF 70 KGRS	M.28		M.30	
TRANSMISSION	GEARS (Hardened and grounded)			
NUMBER AND RANGE OF SPEED (rpm.) 50 Hz.	(8) 75 - 2100			
NUMBER AND RANGE OF SPEED (rpm.) 60 Hz.	(8) 90 - 2520			
FEED	MANUAL			
MAIN MOTOR POWER	1/1,5 HP		1,2/2 HP	
MAIN MOTOR SPEEDS	1.500 rpm			
SPINDLE MORSE TAPER	MT.4			
SPINDLE STROKE mm	160 mm			
DISTANCE SPINDLE-COLUMN mm	300 mm			
DISTANCE SPINDLE-TABLE mm	Min. 70/Max. 885 mm			
DISTANCE SPINDLE-BASE mm	1245 mm			
COLUMN DIAMETER mm	Ø 125 mm			
TABLE DIMENSIONS mm	400X420 mm			
BASE DIMENSIONS mm	400x655 mm	492x655 mm	400x655 mm	492x655 mm
TABLE WITH "T" SLOTS	YES			
ADJUSTABLE DEPTH STOP	YES			
COOLANT EQUIPMENT	NO	YES	NO	YES
TOOL EJECTOR	YES			
LIGHTING EQUIPMENT	YES			
MAIN SWITCH	NO			
EMERGENCY PUSH BUTTON	YES			
SELECTION FOR TURNING DIRECTION	YES			
ELECTRICAL EQUIPMENT AT LOW VOLTAGE	YES			
DRILL GUARD WITH STOP MICRO	YES			
CE NORMS	YES			
WEIGHT: NET / GROSS	280 / 350 Kgrs.			
PACKAGING DIMENSIONS AND VOLUME	1000x600x2400 mm / 1,44 m ³			

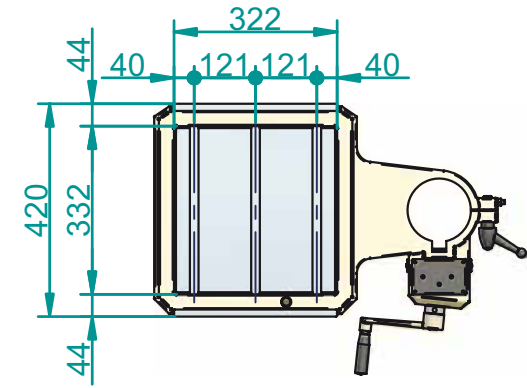
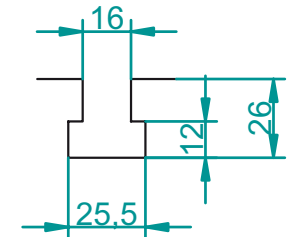
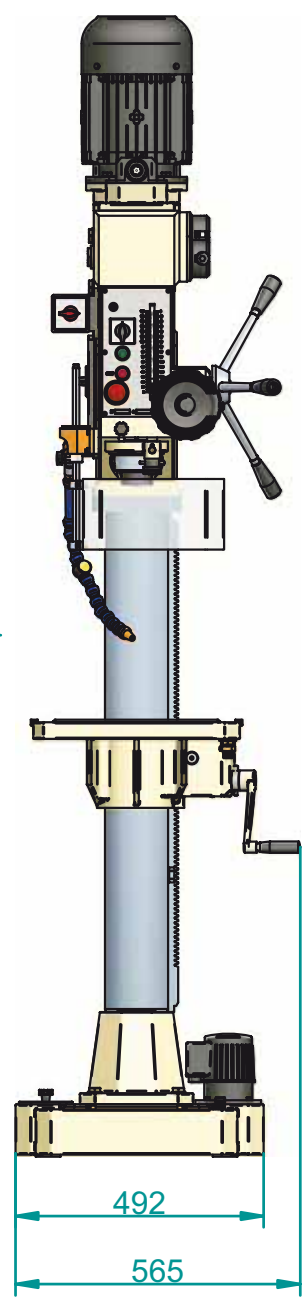
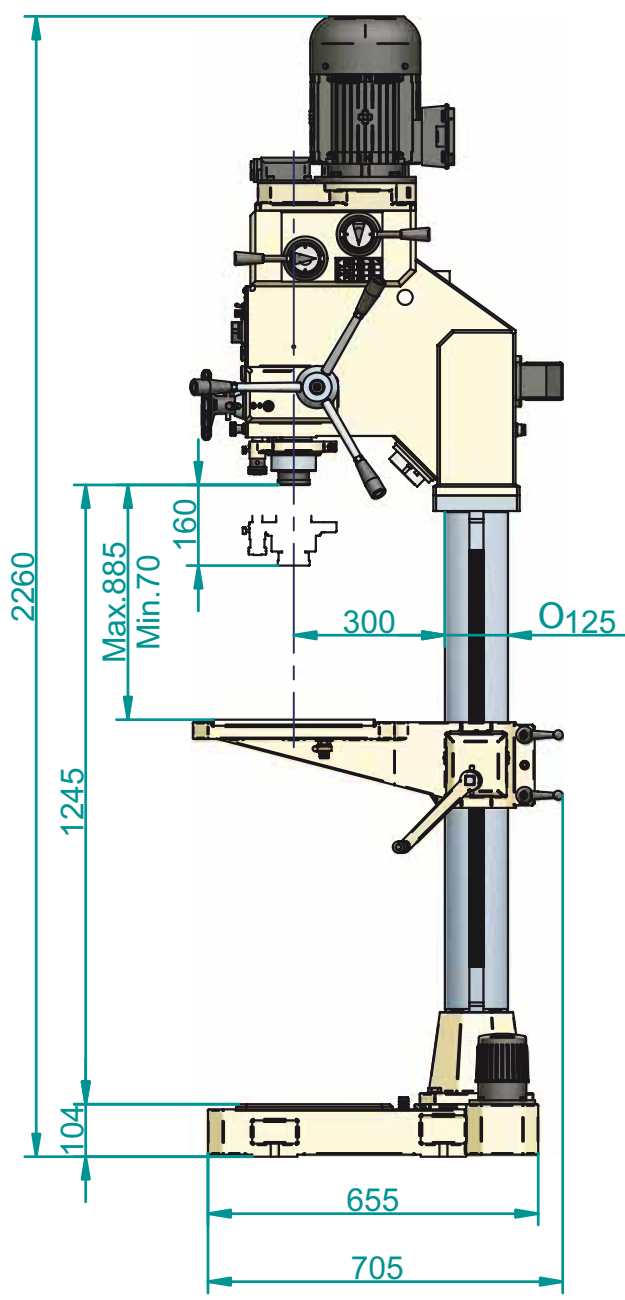

MESA GIRATORIA INCLINABLE
GIRATORY AND TILTING TABLE
TABLE TOURNANTE ET INCLINABLE
DREH UND SCHWENKBARER TISCH

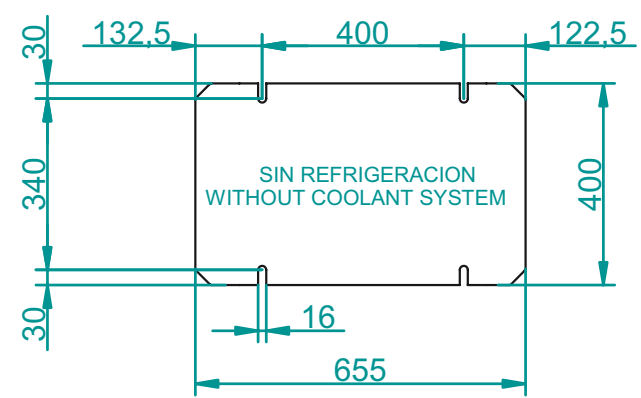
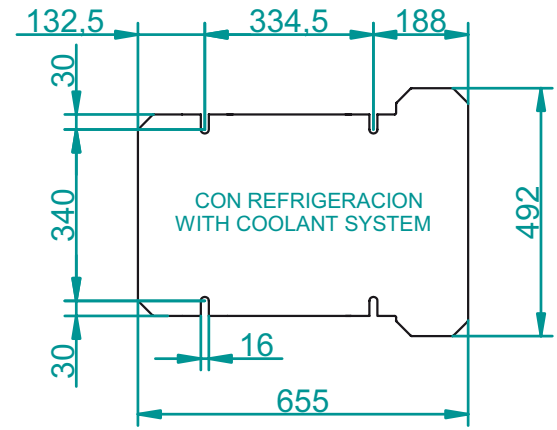
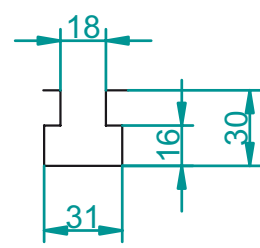
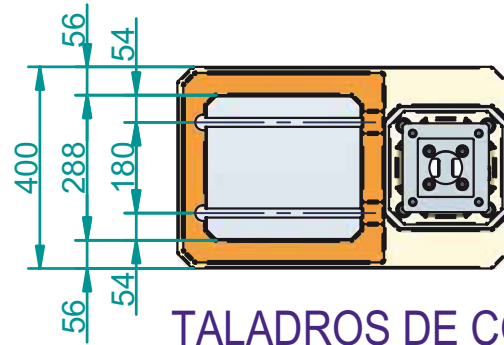
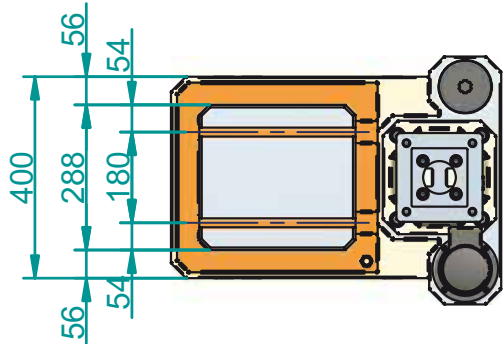
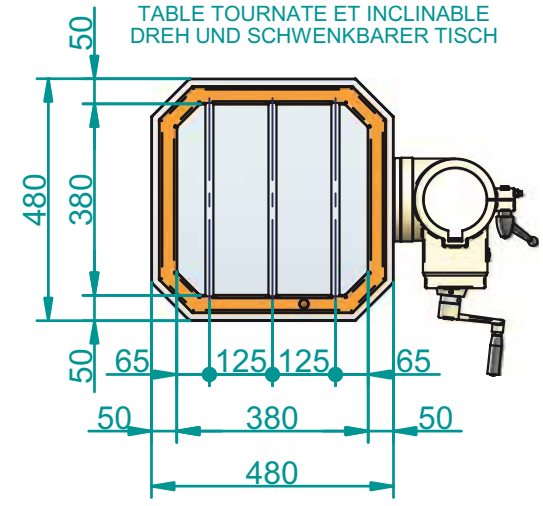

TALADROS DE COLUMNA
SERIE TS-32-35